

Parts List			
ITEM	QTY	PART NUMBER	DESCRIPTION
1	1	ROLL AWAY NEST CABINET	
1.1	2	SIDE	1/2" PLYWOOD
1.2	2	cabinet bottom	1/2" PLYWOOD
1.3	1	back	1/2" PLYWOOD
1.4	2	NEST FACE	1/2" PLYWOOD
1.5	1	EGG DOOR	1/2" PLYWOOD
1.6	3	nest divider	1/2" PLYWOOD
1.7	16	BOTTOM ANGLE	1/2" PLYWOOD
1.8	16	TOP ANGLE	1/2" PLYWOOD
1.9	1	nest bottom	1/2" PLYWOOD
2	16	ramp	1/2" PLYWOOD
3	2	EGG DOOR	1/2" PLYWOOD
4	1	CABINET DOOR	1/2" PLYWOOD

TO REDUCE THE NUMBER OF BOXES:
 CUT ITEMS THE FOLLOWING ITEMS 12" SHORTER FOR EVERY 2 LESS BOXES
 1.1 / 1.2 / 1.3 / 1.4 / 1.5 / 1.9 / 3 / 4
 REMOVE THE FOLLOWING QUANTITIES FOR THE FOLLOWING ITEMS FOR EVERY 2 LESS BOXES
 1.6 (-1) / 1.7 (-4) / 1.8 (-4) / 2 (-4)

TO INCREASE THE NUMBER OF BOXES:
 CUT ITEMS THE FOLLOWING ITEMS 12" LONGER FOR EVERY 2 MORE BOXES
 1.1 / 1.2 / 1.3 / 1.4 / 1.5 / 1.9 / 3 / 4
 ADD THE FOLLOWING QUANTITIES FOR THE FOLLOWING ITEMS FOR EVERY 2 MORE BOXES
 1.6 (+1) / 1.7 (+4) / 1.8 (+4) / 2 (+4)

TO ADD/REMOVE ROWS (QUANTITIES ARE FOR 4 NESTS WIDE UNIT)
 ADD/REMOVE THE FOLLOWING QUANTITIES OF THE FOLLOWING ITEMS
 ITEMS 1.1 1.3 AND 1.6 (18.16") / 1.4 (1) / 1.5 (1) / 1.7 (8) / 1.8 (8) / 1.9 (1) / 2 (8) / 3 (1)

DRAWN BY KWS	3/6/2011	Spline Design Studios	
CLIENT		TITLE	
STANDARD TOLERANCES		Top Level Bill Of Material	
.X	+/- .0625	SIZE 8.5" x 11"	DWG NO NEST BOX (8)
.XX	+/- .0313	SCALE NOT TO SCALE	REV
.XXX	+/- .0156	SHEET 1 OF 13	

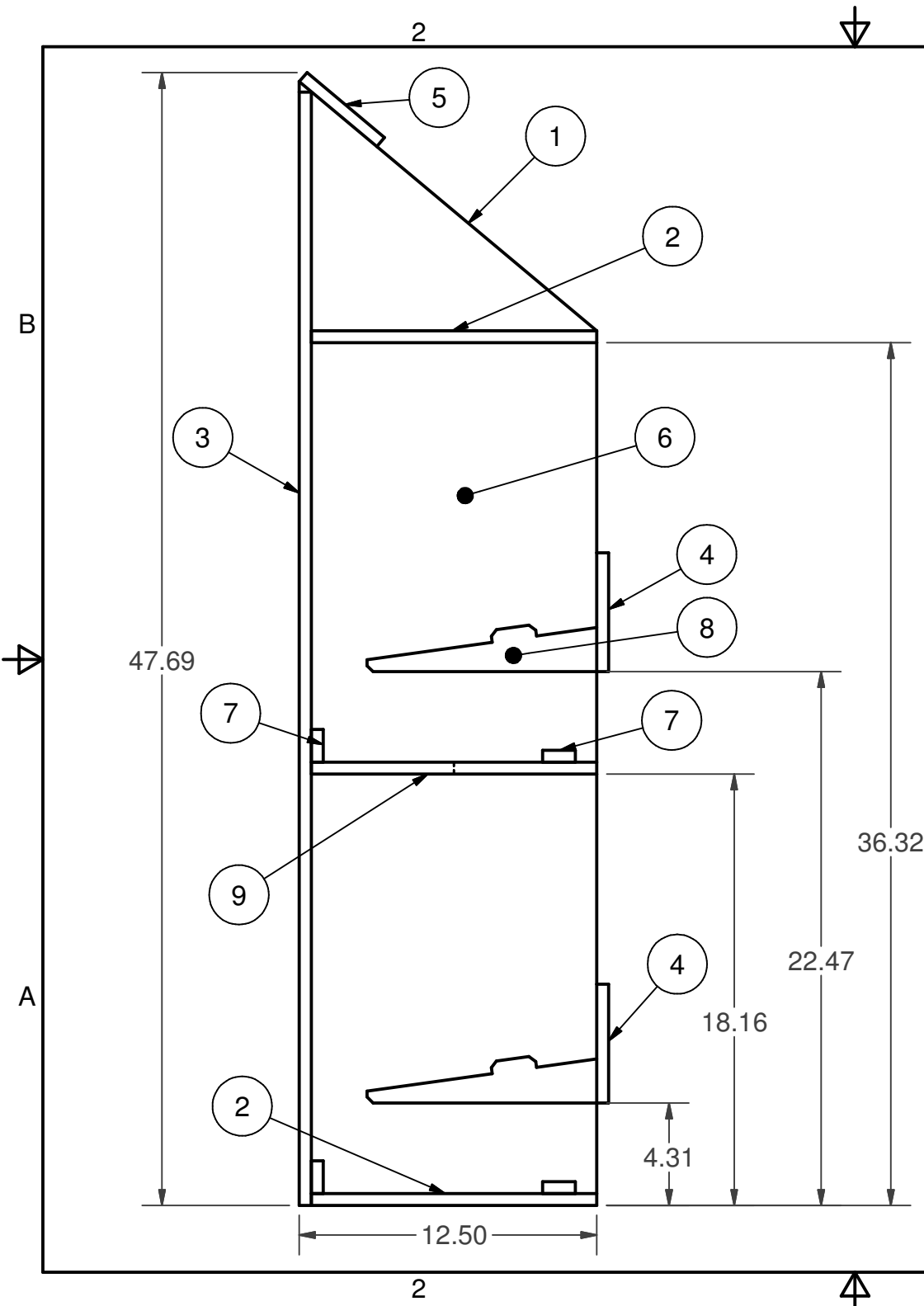

1

Parts List			
ITEM	QTY	PART NUMBER	DESCRIPTION
1	2	SIDE	1/2" PLYWOOD
2	2	cabinet bottom	1/2" PLYWOOD
3	1	back	1/2" PLYWOOD
4	2	NEST FACE	1/2" PLYWOOD
5	1	EGG DOOR	1/2" PLYWOOD
6	3	nest divider	1/2" PLYWOOD
7	16	BOTTOM ANGLE	1/2" PLYWOOD
8	16	TOP ANGLE	1/2" PLYWOOD
9	1	nest bottom	1/2" PLYWOOD

**THIS PRINT IS FOR LAYOUT EXPLANATION
AND CONTAINS ONLY CABINET PARTS -
NO DOORS, HINGES OR PERCHES**

DRAWN BY KWS	3/6/2011	Spline Design Studios	
CLIENT		TITLE	
STANDARD TOLERANCES		Top Level Bill Of Material	
.X +/- .0625		SIZE 8.5" x 11"	DWG NO NEST BOX (8)
.XX +/- .0313		SCALE NOT TO SCALE	REV
.XXX +/- .0156		SHEET 2 OF 13	

2

1

Parts List			
ITEM	QTY	PART NUMBER	DESCRIPTION
1.1	1	SIDE	1/2" PLYWOOD

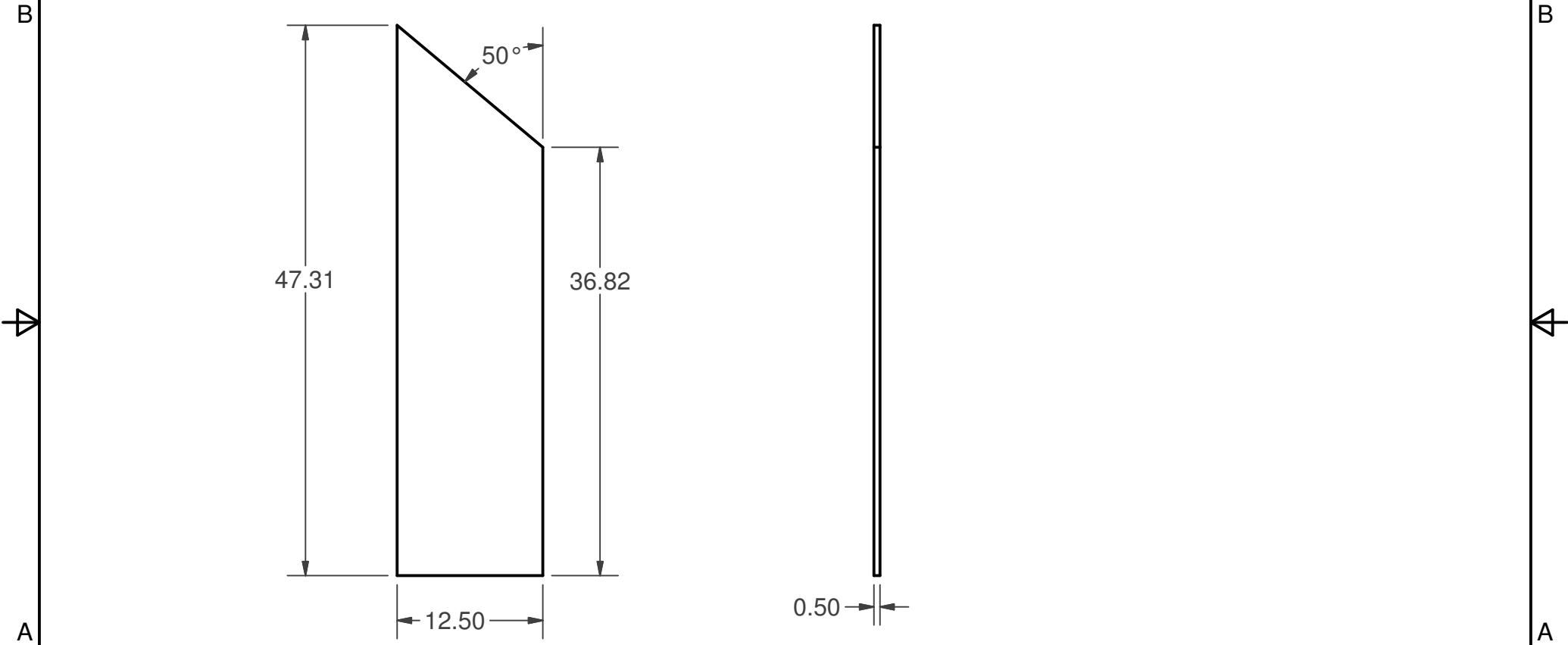

DRAWN BY KWS	3/6/2011	Spline Design Studios	
CLIENT		TITLE Top Level Bill Of Material	
STANDARD TOLERANCES		SIZE 8.5" x 11"	DWG NO NEST BOX (8)
.X	+/- .0625	SCALE NOT TO SCALE	REV
.XX	+/- .0313	SHEET 3 OF 13	
.XXX	+/- .0156		

2



1

Parts List

ITEM	QTY	PART NUMBER	DESCRIPTION
1.2	1	cabinet bottom	1/2" PLYWOOD

B

B

0.50



49.50



12.00

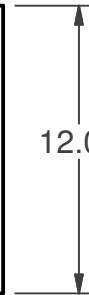

A

A

2



1

DRAWN BY KWS	3/6/2011	Spline Design Studios	
CLIENT		TITLE Top Level Bill Of Material	
<u>STANDARD TOLERANCES</u>		SIZE 8.5" x 11"	DWG NO NEST BOX (8)
.X	+/- .0625	SCALE NOT TO SCALE	REV
.XX	+/- .0313	SHEET 4 OF 13	
.XXX	+/- .0156		

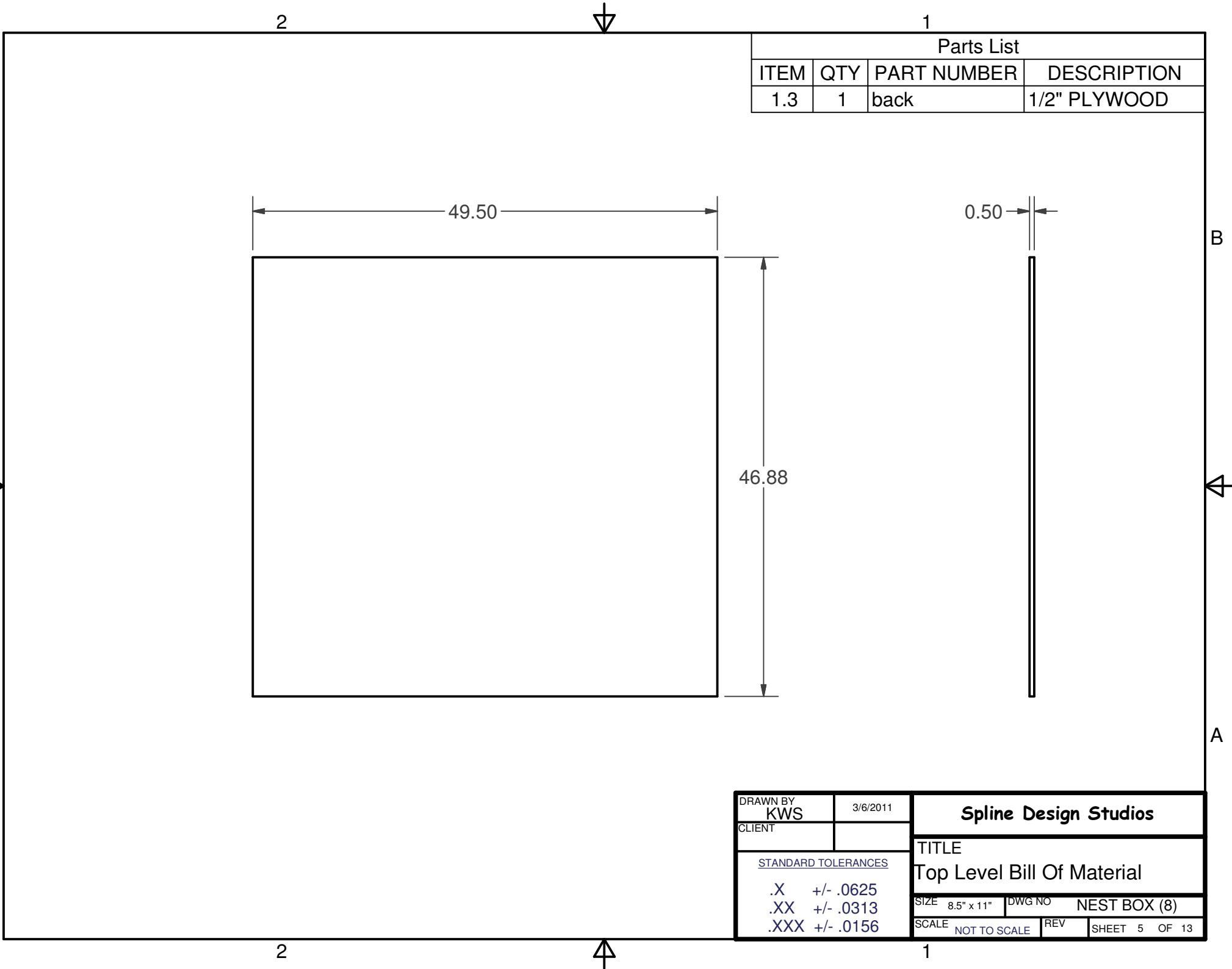

Parts List			
ITEM	QTY	PART NUMBER	DESCRIPTION
1.3	1	back	1/2" PLYWOOD

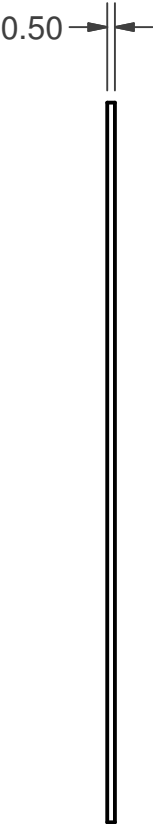
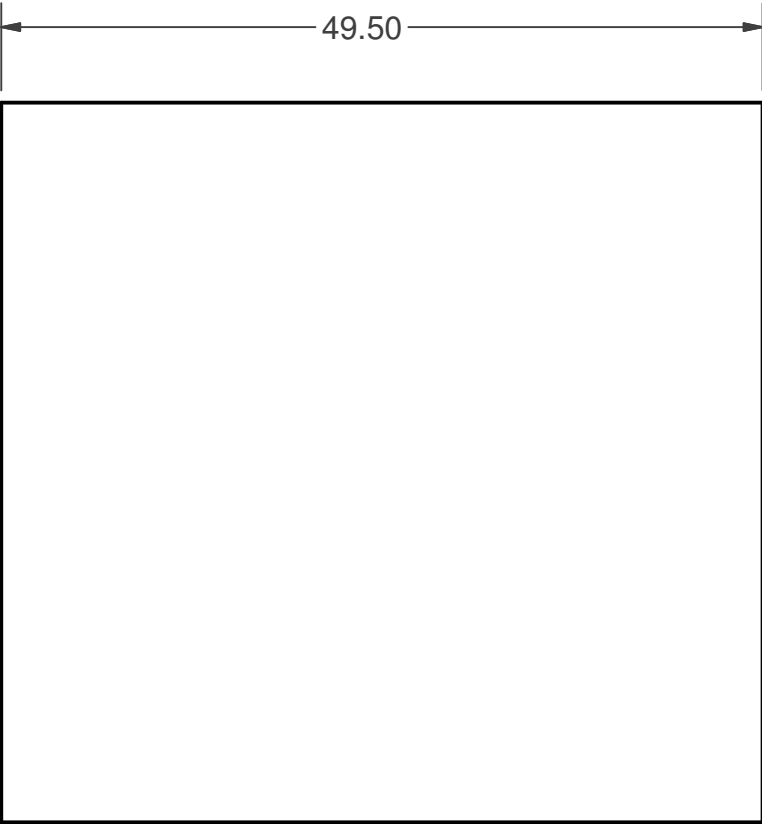

DRAWN BY KWS	3/6/2011	Spline Design Studios	
CLIENT		TITLE Top Level Bill Of Material	
<u>STANDARD TOLERANCES</u>		SIZE 8.5" x 11"	DWG NO NEST BOX (8)
.X +/- .0625	.XX +/- .0313	SCALE NOT TO SCALE	REV SHEET 5 OF 13
.XXX +/- .0156			

2



1

Parts List

ITEM	QTY	PART NUMBER	DESCRIPTION
1.4	1	NEST FACE	1/2" PLYWOOD

B

B

0.50



50.50



5.00

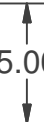

A

A

2



1

DRAWN BY KWS	3/6/2011	Spline Design Studios	
CLIENT		TITLE Top Level Bill Of Material	
STANDARD TOLERANCES		SIZE 8.5" x 11"	DWG NO NEST BOX (8)
.X +/- .0625	.XX +/- .0313	SCALE NOT TO SCALE	REV SHEET 6 OF 13
.XXX +/- .0156			

2



1

Parts List

ITEM	QTY	PART NUMBER	DESCRIPTION
1.5	1	EGG DOOR	1/2" PLYWOOD

B

B



0.50



50.50



4.25



A

A

2



1

DRAWN BY KWS	3/6/2011	Spline Design Studios	
CLIENT		TITLE Top Level Bill Of Material	
<u>STANDARD TOLERANCES</u>		SIZE 8.5" x 11"	DWG NO NEST BOX (8)
.X +/- .0625		SCALE NOT TO SCALE	REV
.XX +/- .0313		SHEET 7 OF 13	
.XXX +/- .0156			

2

1



Parts List

ITEM	QTY	PART NUMBER	DESCRIPTION
1.6	1	nest divider	1/2" PLYWOOD

B

B

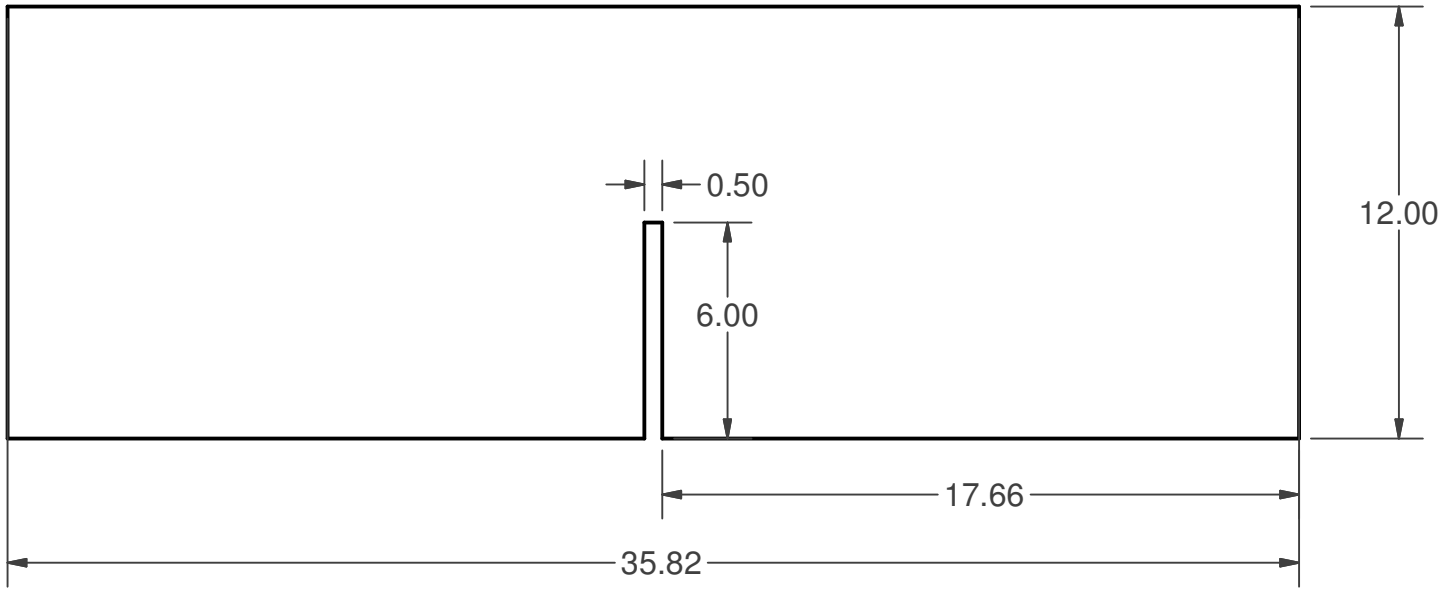
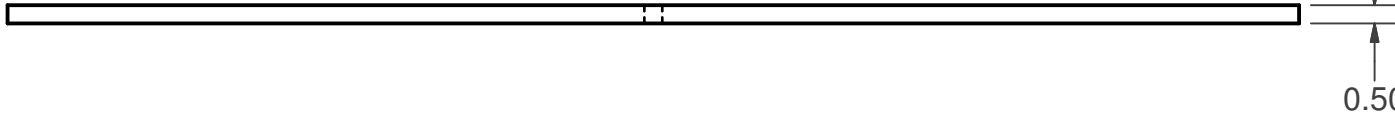

A

A



2

1

DRAWN BY KWS	3/6/2011	Spline Design Studios	
CLIENT		TITLE Top Level Bill Of Material	
<u>STANDARD TOLERANCES</u>		SIZE 8.5" x 11"	DWG NO NEST BOX (8)
.X +/- .0625		SCALE NOT TO SCALE	REV
.XX +/- .0313		SHEET 8 OF 13	
.XXX +/- .0156			

2



1

Parts List

ITEM	QTY	PART NUMBER	DESCRIPTION
1.7	1	BOTTOM ANGLE	1/2" PLYWOOD

B

B

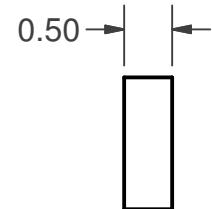
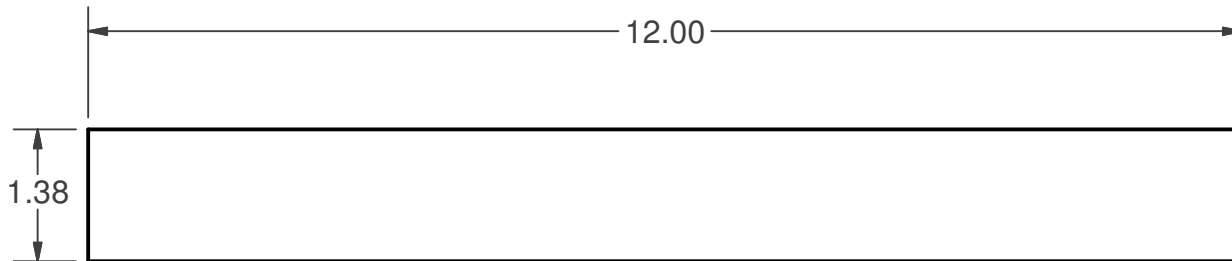

A

A

2



1

DRAWN BY KWS	3/6/2011	Spline Design Studios	
CLIENT		TITLE Top Level Bill Of Material	
<u>STANDARD TOLERANCES</u>		SIZE 8.5" x 11"	DWG NO NEST BOX (8)
.X +/- .0625	.XX +/- .0313	SCALE NOT TO SCALE	REV SHEET 9 OF 13
.XXX +/- .0156			

2



1

Parts List			
ITEM	QTY	PART NUMBER	DESCRIPTION
1.8	1	TOP ANGLE	1/2" PLYWOOD

B

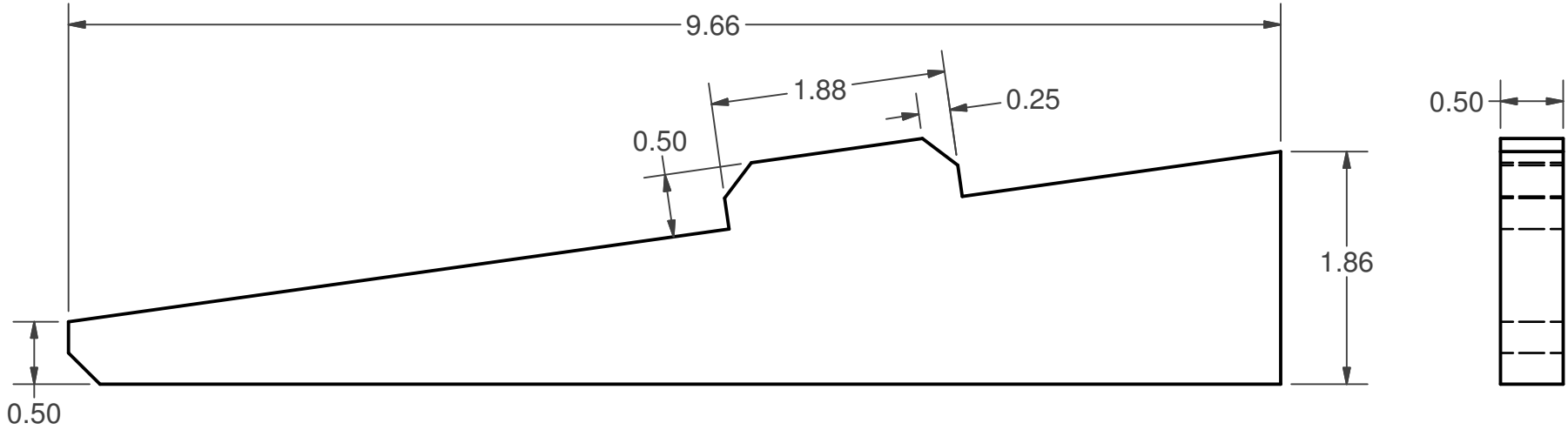

B



1 to 1 Cut Template

A

A

2



1

DRAWN BY KWS	3/6/2011	Spline Design Studios	
CLIENT		TITLE Top Level Bill Of Material	
<u>STANDARD TOLERANCES</u>		SIZE 8.5" x 11"	DWG NO NEST BOX (8)
.X	+/- .0625	SCALE NOT TO SCALE	REV
.XX	+/- .0313	SHEET 10 OF 13	
.XXX	+/- .0156		

2



1

Parts List

ITEM	QTY	PART NUMBER	DESCRIPTION
1.9	1	nest bottom	1/2" PLYWOOD

B

B

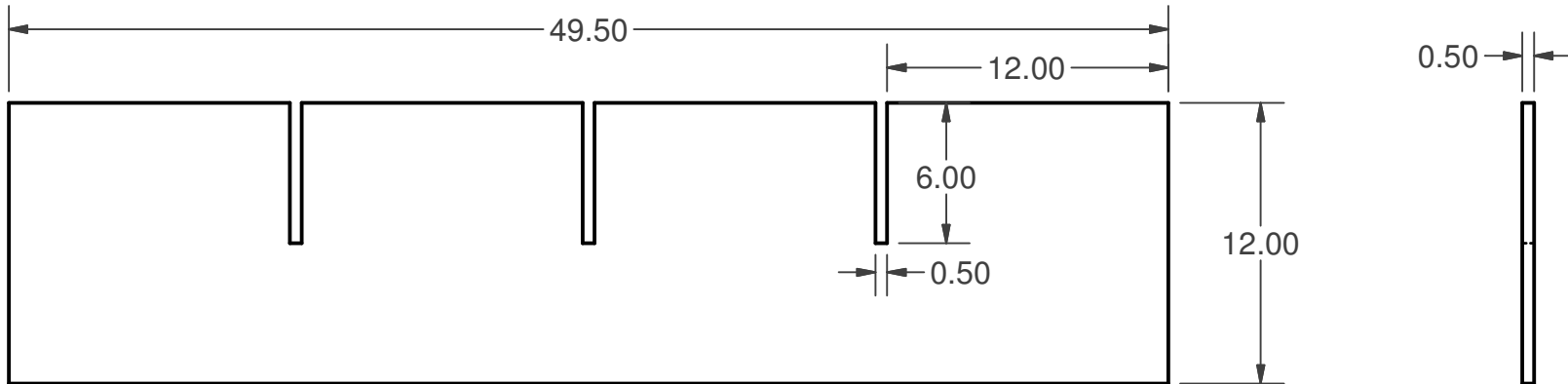

A

A

2



1

DRAWN BY KWS	3/6/2011	Spline Design Studios	
CLIENT		TITLE Top Level Bill Of Material	
STANDARD TOLERANCES		SIZE 8.5" x 11"	DWG NO NEST BOX (8)
.X +/- .0625	.XX +/- .0313	SCALE NOT TO SCALE	REV
.XXX +/- .0156		SHEET 11 OF 13	

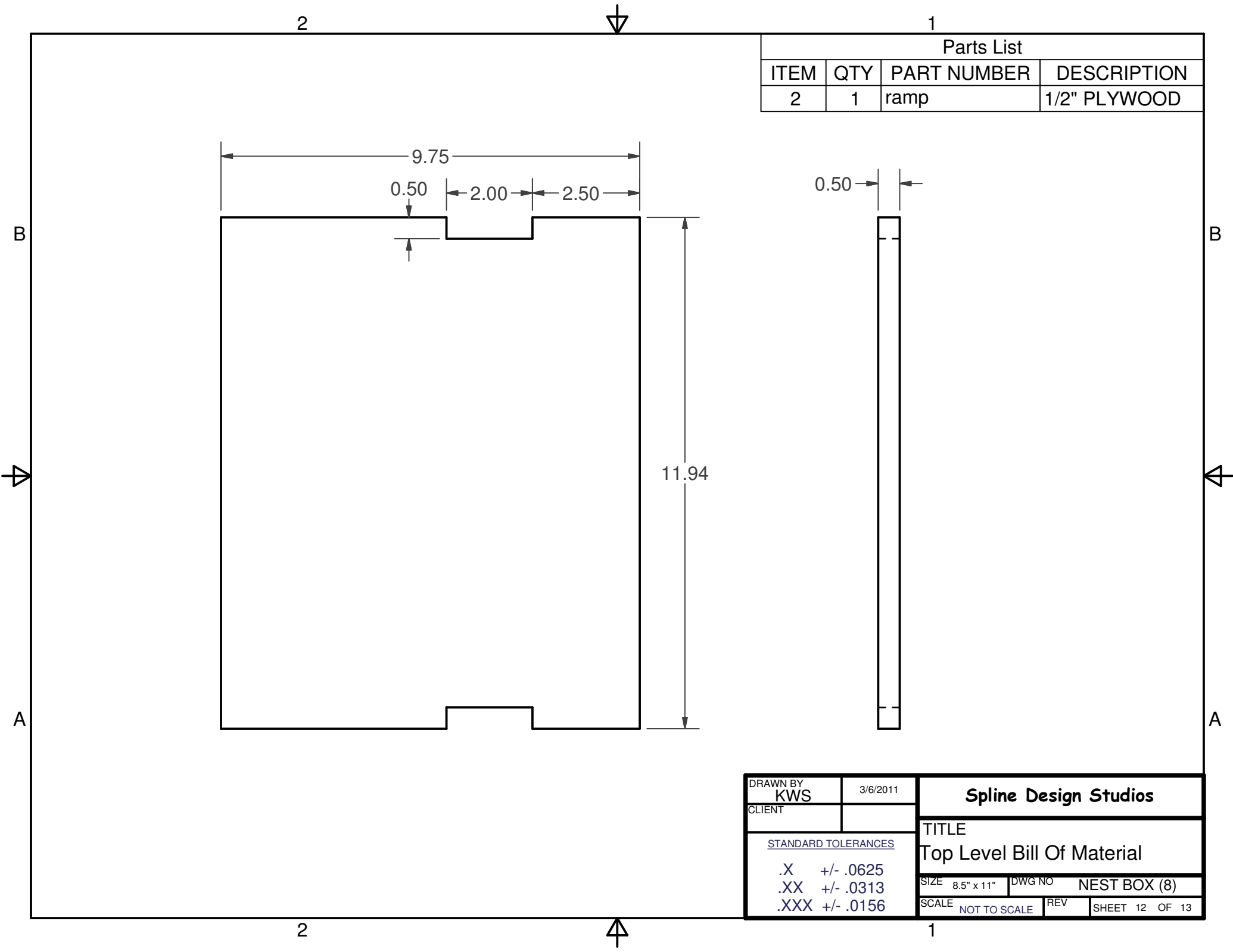

Parts List			
ITEM	QTY	PART NUMBER	DESCRIPTION
2	1	ramp	1/2" PLYWOOD

DRAWN BY KWS	3/6/2011	Spline Design Studios	
CLIENT		TITLE Top Level Bill Of Material	
STANDARD TOLERANCES		SIZE 8.5" x 11"	DWG NO NEST BOX (8)
.X	+/- .0625	SCALE NOT TO SCALE	REV
.XX	+/- .0313	SHEET 12 OF 13	
.XXX	+/- .0156		

2



1

Parts List

ITEM	QTY	PART NUMBER	DESCRIPTION
4	1	CABINET DOOR	1/2" PLYWOOD

B

B

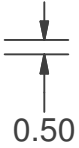

0.50



50.50

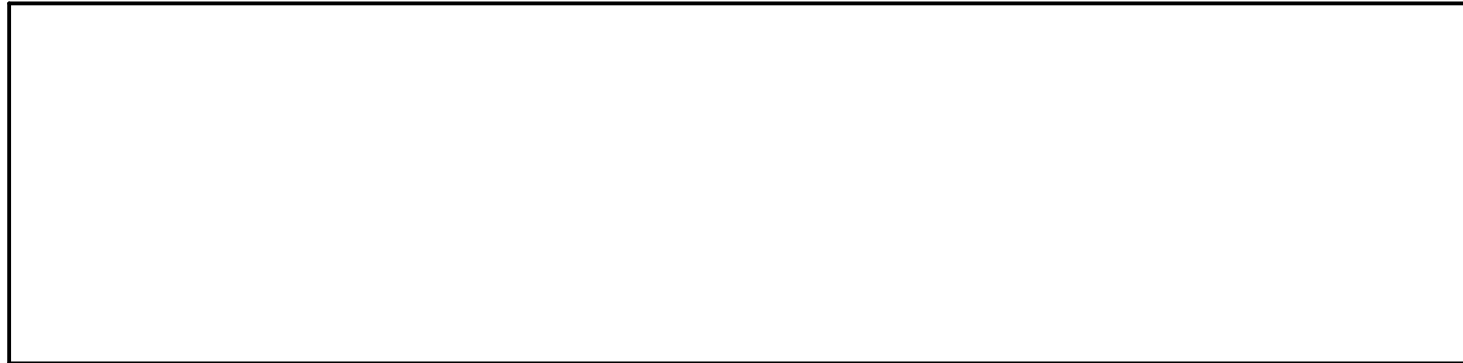

12.50



A

A

2



1

DRAWN BY KWS	3/6/2011	Spline Design Studios	
CLIENT		TITLE Top Level Bill Of Material	
STANDARD TOLERANCES		SIZE 8.5" x 11"	DWG NO NEST BOX (8)
.X +/- .0625	.XX +/- .0313	SCALE NOT TO SCALE	REV SHEET 13 OF 13
.XXX +/- .0156			